

# SRL-49

SIMPACT II

- process meter with bargraph
- input 0/4-20 mA, 0/1-5V, 0/2-10V
- 0, 2 or 4 relay outputs (or OC)
- RS-485 / Modbus RTU
- option: active current output



The **SRL-49** process meter features current input with protection safeguarding the measuring resistor against damage. The measurement is visible simultaneously on the 4-decade LED display and 20-point, two-colour bargraph reflecting 0-100% of measuring range. The set threshold values are also shown on the bargraph, and the LEDs indicate when the values are exceeded. The device operates in the following modes: linear, root, square and user defined (max. 20 points). 2 or 4 relay (or OC) outputs enable adjustment of the level of the measured signal. These outputs can be controlled according to one or two threshold values.

- programmable measuring range,
- programmable hystereses and delays of control outputs,
- password protected,
- programmable indication filtration,
- overload-protected current input.

## Typical applications

1. Measurement of pressure in pipelines with air pressure control by means of the frequency inverter and signalling of minimum and maximum thresholds.

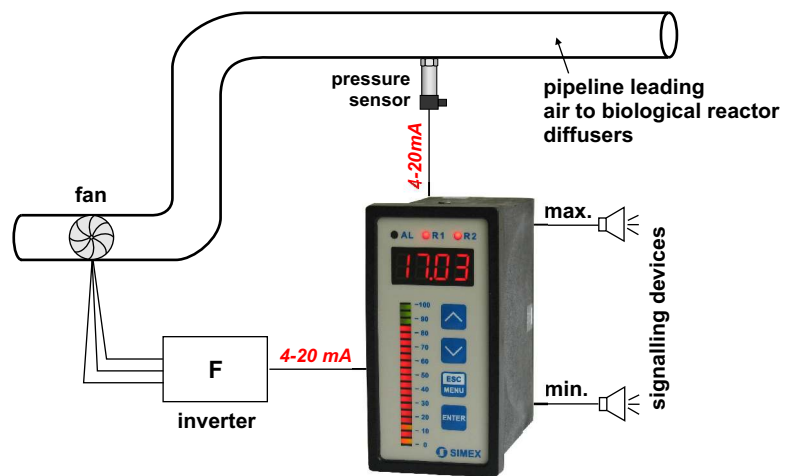

## Exemplary pin assignment

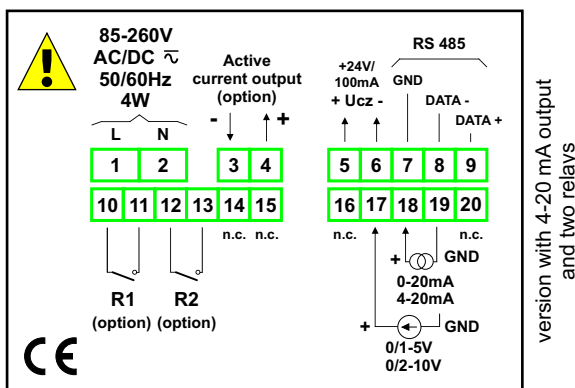

## Technical data

- Power supply:** 19V + 50V DC; 16V + 35V AC or 85 + 260V AC/DC
- Power consumption:** for 85 + 260V AC/DC and 16V + 35V AC power supply: max. 4,5 VA; 19V + 50V DC power supply: max. 4,5 W
- Display:** LED, red, 4 x 9 mm high + 20-points bargraph, red-green
- Input:** current 0-20 mA or 4-20 mA, programmable, input resistance < 65 Ω (typ. 55 Ω), overload-protected, input current limited to 40 mA; voltage 0-5 V, 1-5V, 0-10V or 2-10V, programmable, input resistance > 50 kΩ
- Displayed values range:** -999 - 9999 + decimal point
- Accuracy:** ± 0,25% ± one digit in the entire operation range
- Outputs:** 0, 2 or 4; relays 1A/250V AC (cosφ=1) or the OC 30mA/30VDC/100mW
- Transducer power supply output:** 24V DC +5%, -10% / max. 100 mA, stabilized, not insulated from measuring inputs
- Active current output:** operating range max. 0 - 24 mA, load resistance max. 700 Ω (option available with 2 relays, see ordering)
- Communication interface:** RS-485, 8N1 and 8N2, 1200 bit/s + 115200 bit/s, Modbus RTU, not galvanically isolated from measuring inputs
- Operating temperature:** 0°C + +50°C
- Storage temperature:** -10°C + +70°C
- Protection class:** IP 65 (front side when an additional frame is installed); IP 40 (front side); IP 20 (case and connection clips)
- Case:** board
- Case material:** NORYL - GFN2S E1
- Case dimensions:** 48 x 96 x 100 mm
- Panel cut-out dimensions:** 43 x 90,5 mm
- Installation depth:** min. 102 mm
- Board thickness:** max. 5 mm

## Ordering

